

**NOTE:**

1. TERMINALS 1 & 2 MUST BE CONNECTED USING THE TWO LARGER GAUGE WIRES OF THE 8-WIRE CABLE.
2. "X" DENOTES WIRING CONNECTION TO THE P.C. BOARD.
3. .... DENOTES MECHANICAL CONNECTION TO METER.

**SERIES 1**

\* (F-2 3A FUSE, 110V/1A Slo-Blo, 22V)

Figure 9  
Wiring Schematic

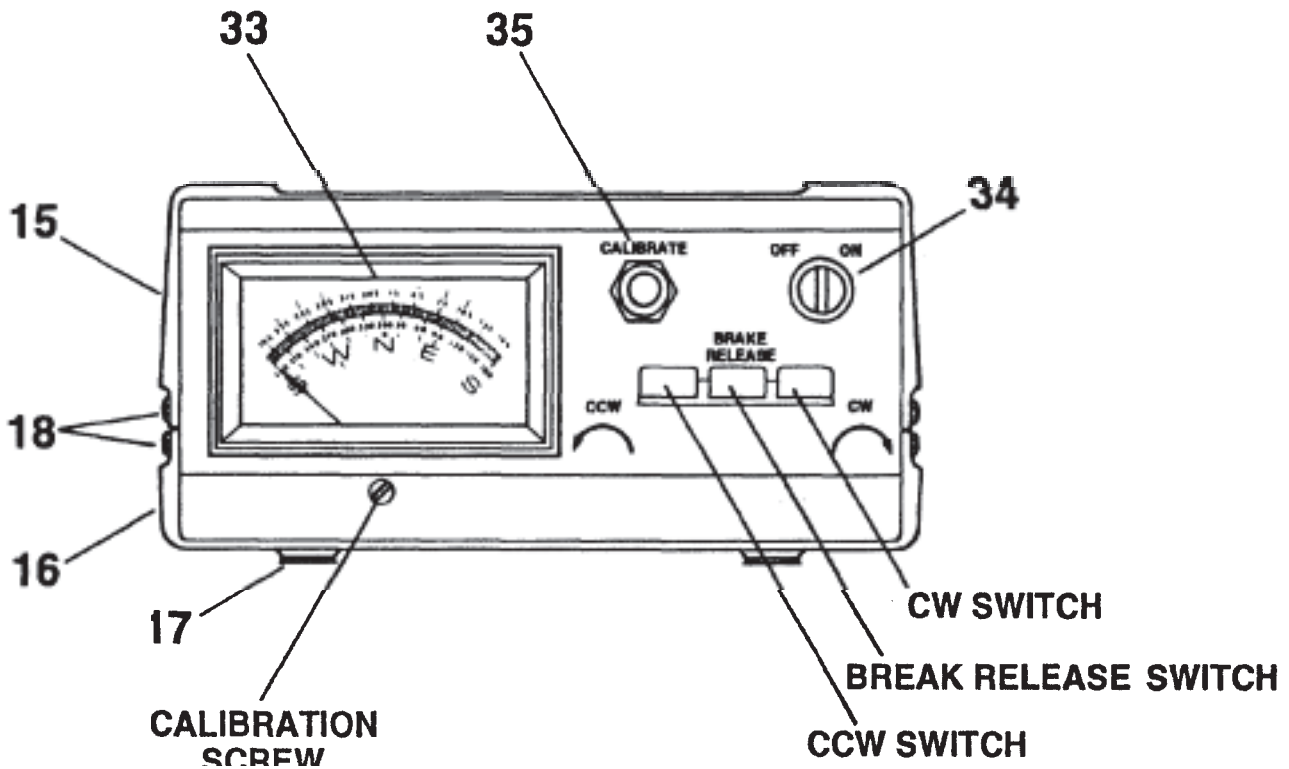

Figure 10  
Control Unit - Front Panel